

Physics holiday questions

s.4

2020

Week one

PRESSURE

1. (a) Define the term pressure and state its S.I unit.
- (b) (i) Explain why a tractor can easily move in muddy areas than the bicycle.
(ii) Explain why one feels more pain when pinched with a needle than a nail.
- (c) State the assumption of pressure made in solids.
- (d) A force of 20N is exerted on an object of cross sectional area 2m^2 . Calculate the pressure exerted on the object.
- (e) A force of 50N is exerted on a ball of cross sectional area 4m^2 . Calculate the pressure.
- (f) The pressure exerted on an object of 5cm^2 is 100Nm^{-2} . Calculate the force exerted on the object.
- (g) A box measures 5m by 2m by 1m and has a weight of 40N. Calculate
 - (i) Minimum pressure.
 - (ii) Maximum pressure.

(h)

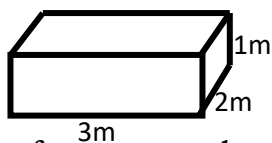

If the force exerted on a box is 24N. Calculate

- (i) Minimum pressure.
 - (ii) Maximum pressure.
- (i) Explain why it is easier to cut meat with a sharp knife than with a blunt edge.
2. (a) Show that the pressure in liquids is given by $P = h\rho g$.
 - (b) State the factors affecting pressure in liquids.
 - (c) A liquid of density 100kgm^{-3} was poured in a container to a depth of 20m. (Take $g = 10\text{ms}^{-1}$). Calculate the pressure the liquid exerts at the bottom of the container.

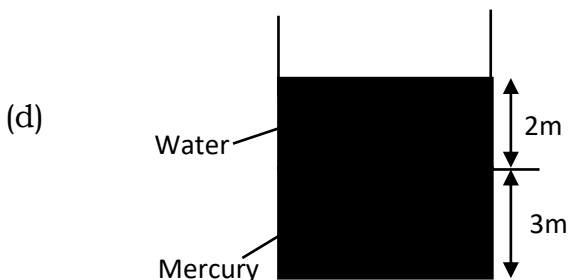

If the density of mercury is 13600kgm^{-3} and the density of water being 1000kgm^{-3} . Calculate the pressure exerted at point A.

- (e) (i) Describe an experiment to show that pressure in liquids increases with increase in depth.
- (ii) Describe an experiment to show that pressure is independent of the cross sectional area.

- (iii) Describe an experiment to show that pressure is equally transmitted through out the liquid.
- (f) State Pascal's principle or law of liquid pressure.
- (g) State the assumption of Pascal's principle.

3. (a) Outline the applications of Pascal's principle.

(b)

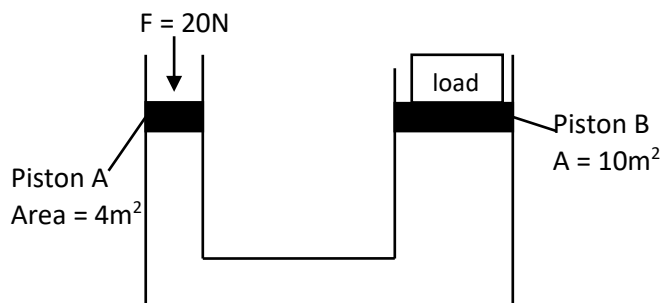

Calculate the weight of the load.

- (c) Calculate the weight, W , raised by a force of 40N applied on a small piston area of 10m^2 and the large piston having area of 20m^2 .
 - (d) A force of 100N applied on a piston of area 5m^2 is used to lift a load, W , with a large piston area of 25m^2 . Calculate the value of W .
 - (e) State the principle of transmission of pressure in liquids.
4. (a) Describe an experiment to demonstrate the existence of pressure using a crushing can.
- (b) Name the pressure the air exerts on the earth's surface.
 - (c) With the aid of a diagram explain how a simple barometer can be used to measure atmospheric pressure.
 - (d)

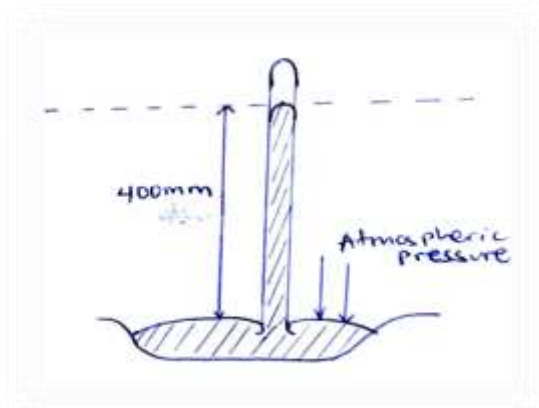

Calculate the atmospheric pressure

- (i) in cmHg.
 - (ii) Pascal or Nm^{-2}
- (e) Given that the atmospheric pressure of mercury is 76cmHg and the density of mercury 13600kgm^{-3} . Calculate the atmospheric pressure in Nm^{-2} or Pascal.
- (f) (i) The column of mercury supported by the atmospheric pressure is 76cm. Find the

column of water supported by atmospheric pressure in the same place.

(ii) Explain why water is not used in a barometer using the answer in (i).

5. (a) Outline the applications of atmospheric pressure.
(b) Explain briefly how a person is able to drink using a straw.
(c) With the aid of a diagram, explain the mode of operation of lift pump or common pump.
(d) With the aid of a diagram, explain the mode of operation of a force pump.
(e) With the aid of a diagram, explain how a bicycle pump works.
6. (a) With the aid of a diagram, explain how a manometer can be used to measure the fluid pressure.
(b)

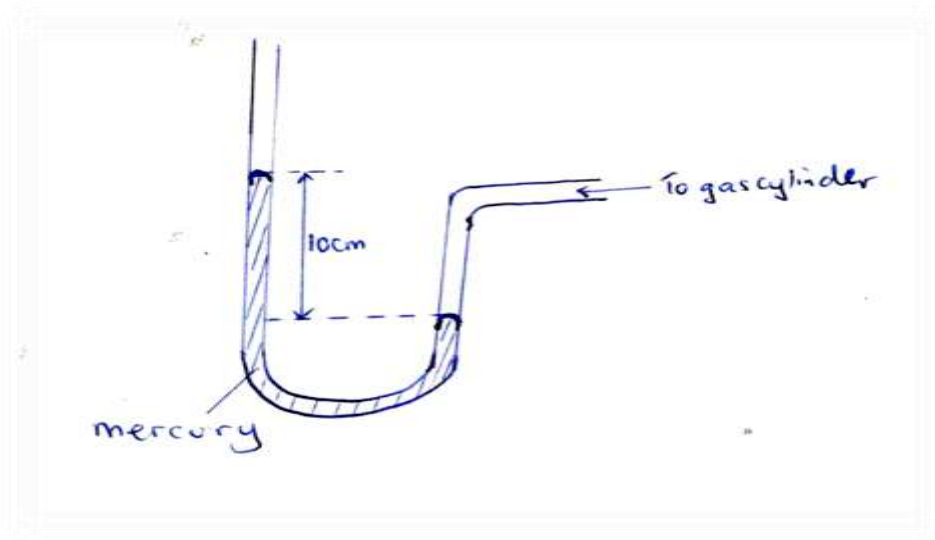

Find the gas pressure if the atmospheric pressure $H = 76\text{cmHg}$ and density of mercury 13600kgm^{-3}

- (i) in cmHg
(ii) in Nm^{-2}

(c)

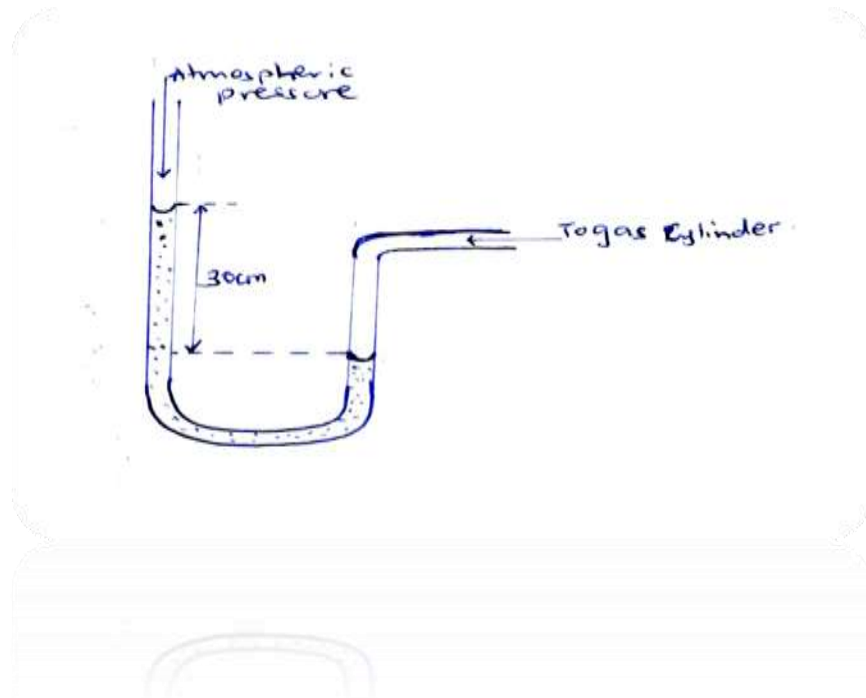

If the density of water is 1000kgm^{-3} and $H = 76\text{cmHg}$. Calculate pressure in Nm^{-2} .

7. (a) Describe an experiment to demonstrate how manometer can be used in comparison or comparing density of two liquids.

(b)

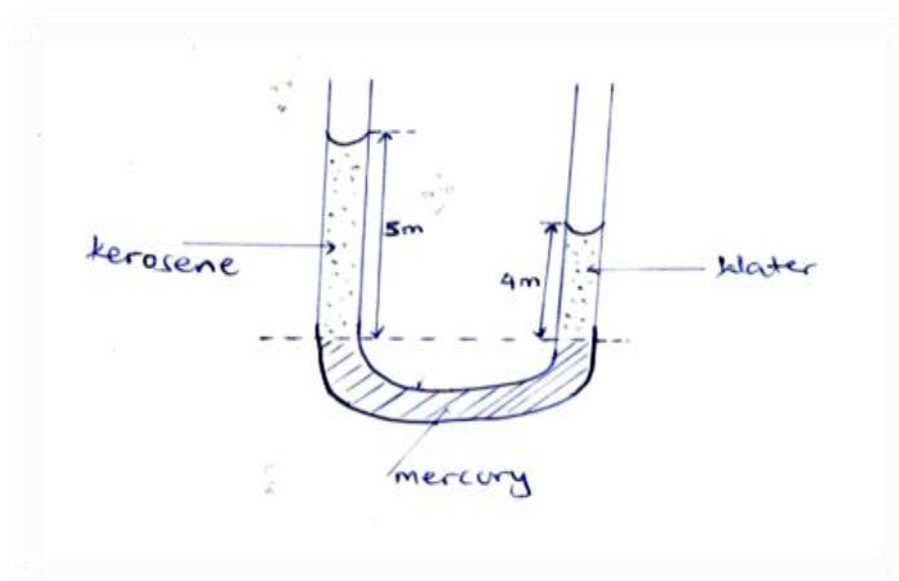

If the density of water is 1000kgm^{-3} . Calculate;

- (i) The density of kerosene.
- (ii) The relative density of kerosene.

(c)

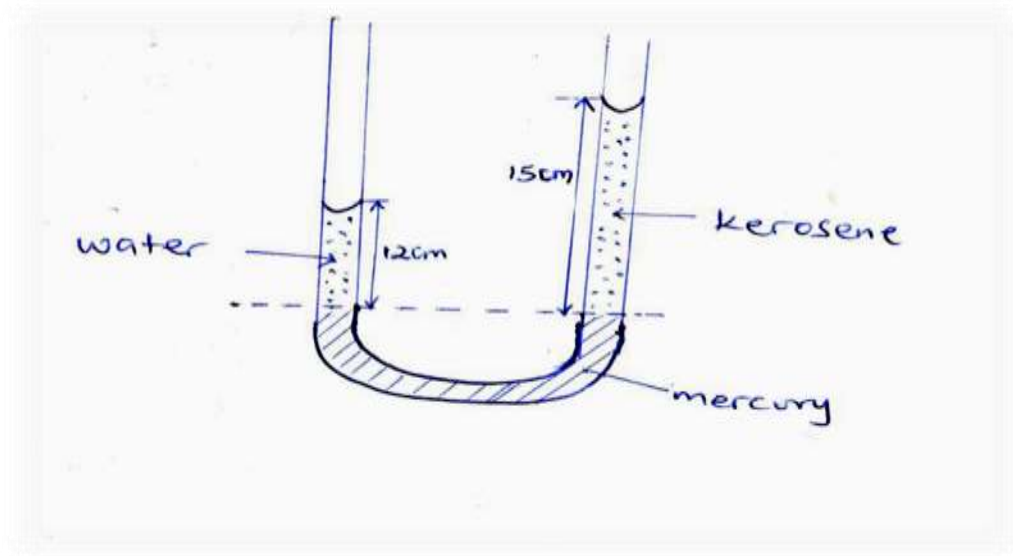

If the density of water is 1000kgm^{-3} calculate

- (i) The density of kerosene.
- (ii) Relative density of kerosene.

(c)

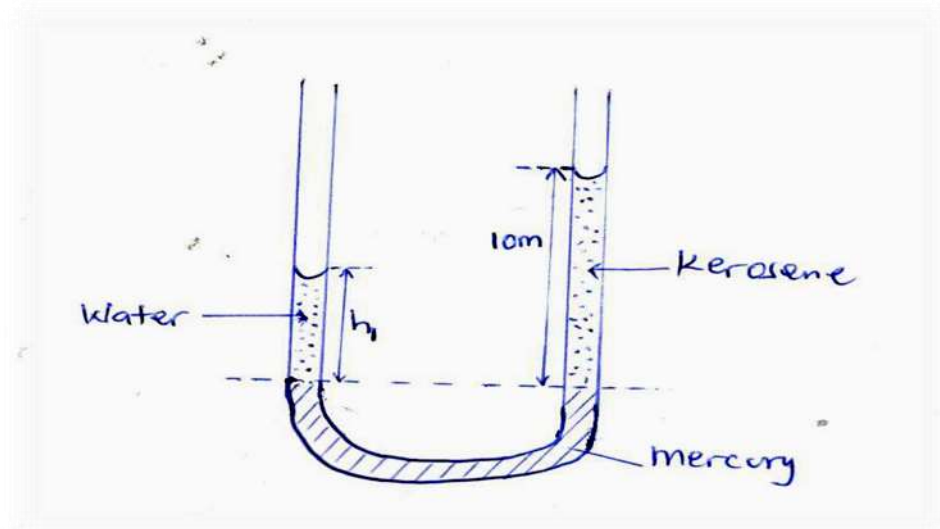

If the density of water is 1000kgm^{-3} and density of kerosene being 800kgm^{-3} , calculate the height h_1

- d) i) Define **Atmospheric pressure**.

- ii) A U-tube manometer is partly filled with water. When a student blows hard into one arm, the level of water on that side goes down by 22.3cm while the level of water in the other arm rises by the same length. Determine the pressure the student exerts on the water if atmospheric pressure is $1.0 \times 10^5 \text{NM}^{-2}$.

MOMENTS AND COUPLES

1. a) Define **moment of force**.
- b) The diagram in Fig 1 below shows a uniform bar AB of length 1.0m and Mass 2.5kg pivoted at point P. if the bar is in equilibrium under the action of a single force of 10N, determine the position of its centre of gravity.

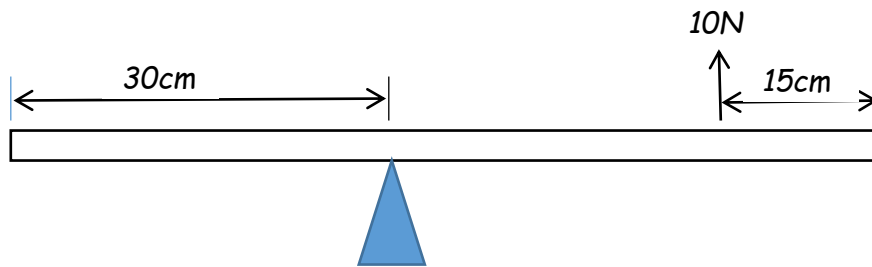

- c) i) Define **centre of gravity**.
- ii) Explain why half-filled jerry can of water is more stable than the same jerry can when full.
- iii) Describe an experiment to determine the centre of gravity of an irregular shaped lamina.
- 2 (a) Define moment of a force.
- (b) State the principle of moment of force.
- (c) Describe an experiment to determine the mass of a uniform metre rule. (Principle of moment)

(d)

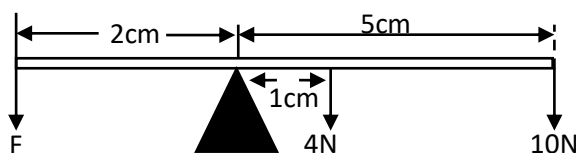

Calculate the value of F.

- 3 (a) A uniform beam 2m long is suspended as shown below.

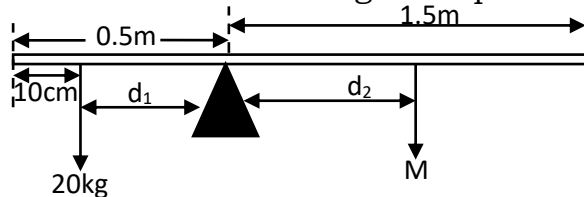

Calculate the mass of M.

- 4 In the following figure, the system is in equilibrium. Find the value of force, F.

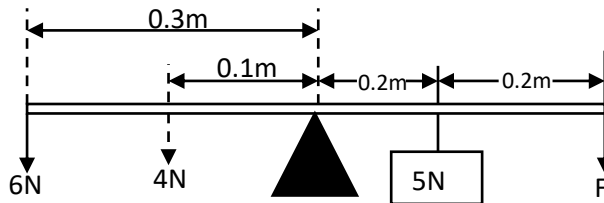

- 5 Find the value of the reaction R and force P in the following diagram.

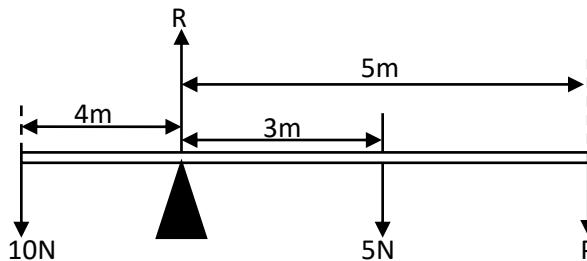

- 6 A uniform metre rule is pivoted at 20cm mark as shown. Find the weight of meter rule.

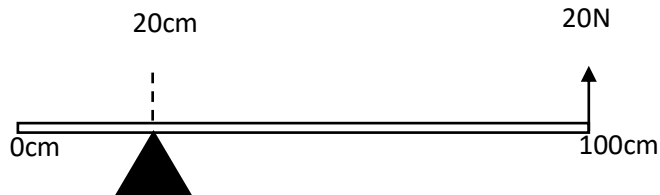

- 7 A uniform metre rule is balanced horizontally on a pivot at the 15cm mark when a load of 7N is attached at the zero mark as shown below. Find the weight of the metre rule.

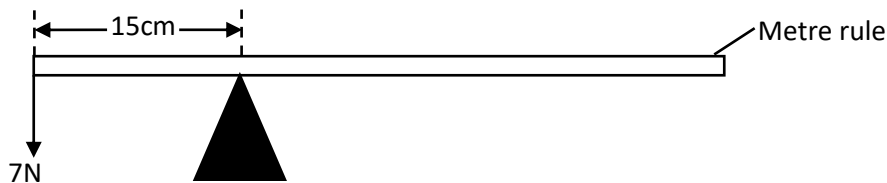

- 8 In the diagram below, the body is in equilibrium. Determine the value of W

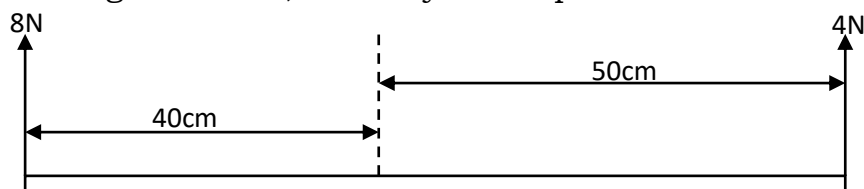

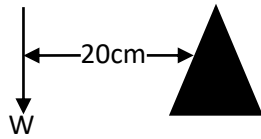

- 9 A uniform metre rule is suspended from 20cm as shown below. If the metre rule is in equilibrium, find its weight.

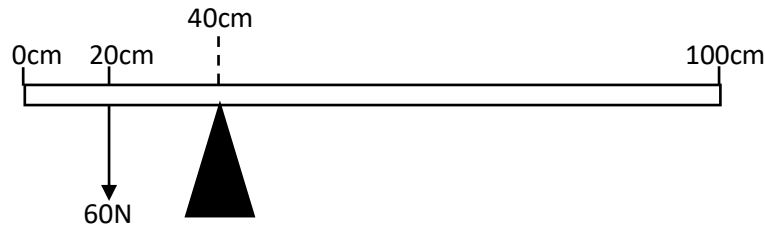

- 10 (a) Describe an experiment to determine the mass of a uniform metre rule.
 (b) A uniform metre rule is balanced at 30cm mark when a load of 0.8m is hang at the zero mark. Find the weight of the metre rule.
 (c) State the condition for a body to be in equilibrium.
 (d) Explain why bus passengers' luggage is loaded in the boots rather than on top of the bus.
- 11 (a) State the condition for a body to be in
 (i) Stable equilibrium.
 (ii) Unstable equilibrium.
 (iii) Neutral equilibrium.
 (b) State the ways of increasing stability of a body.
 (c) define a couple
 (d) define torque and state its s.I unit

Week 2

MACHINES

- d) In an experiment to determine the variation of efficiency of a pulley system of known velocity ratio with load, known weights are gradually suspended on the lower block.
 i) Sketch a graph of efficiency against load.
 ii) Explain the features of the graph.
- e) The diagram in fig 2 shows a load of 1500N being raised by pulling it along an inclined plane of length 5.0m by a force of 600N.

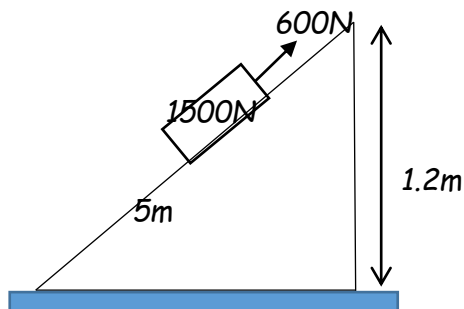

determine the;

- i) Work done by effort

- ii) work done on the load
 - iii) efficiency of the machine
- 1.
- (a) Define the following terms as used in machines.
 - (i) Mechanical advantage.
 - (ii) Velocity ratio.
 - (iii) Efficiency.
 - (b)
 - (i) When is the mechanical advantage greater than one?
 - (ii) When is the mechanical advantage less than one?
 - (c) Calculate the mechanical advantage when an effort of 20N is used to lift a load of 120N.
 - (d) A force of 40N is used to lift a load of 240N. Calculate the mechanical advantage.
 - (a) A load of 200N is lifted through 5m when an effort of 50N moves through a distance of 25m. Calculate
 - (i) Mechanical advantage.
 - (ii) Velocity ratio.
 - (iii) Efficiency of the system.
 - (f) A simple machine of velocity ratio 4 needs an effort of 50N to raise a load of 150N. Calculate;
 - (i) Mechanical advantage.
 - (ii) Efficiency.
 - (iii) Sketch a graph of mechanical advantage against load.
 - (g) An effort of 250N moves a load of 500N through 10m. If the effort moved through 30m, calculate
 - (i) The work done by the load.
 - (ii) The work done by the effort.
 - (iii) The efficiency of the system.
 - (h) Give reasons why the efficiency of a machine is less than 100%.
 - (i) Give the ways of increasing the efficiency of a machine.
- 2.
- (a)
 - (i) Outline the examples of first class lever.
 - (ii) Outline the examples of second class lever.
 - (b) Give some applications of pulleys.
 - (c)
 - (i) Give reasons why efficiency of pulley system is less than 100%.
 - (ii) Give ways of improving efficiency of a pulley system.
 - (d) Draw the following pulley systems.
 - (i) 2 pulley system.
 - (ii) 3 pulley system.
 - (iii) 5 pulley system.

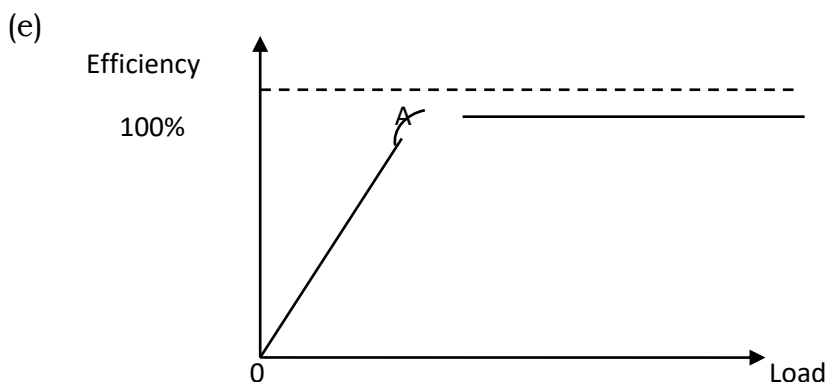

Explain the behaviour of the curve.

- (i) Between OA (ii) At A.
- (f) An effort of 50N is required to lift a load of 150N using a pulley system of V.R 4.
- (i) Draw a diagram to show the pulley system.
- (ii) Find the efficiency.
- (iii) Calculate the work wasted when the load is raised through 8m.

(g)

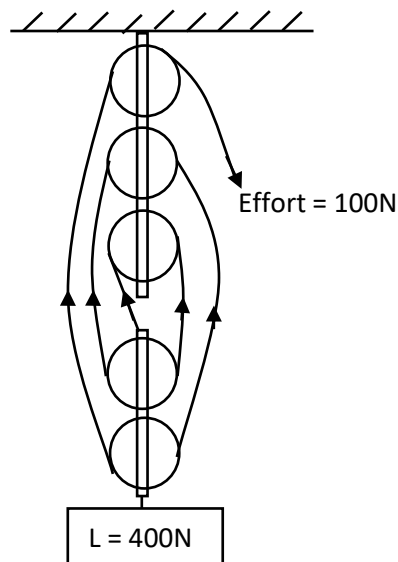

A load of 400N is lifted using an effort of 100N find

- (i) Efficiency of the system.
- (ii) Work wasted when the load is raised through 3m.
3. (a) A lorry of 100N is pulled up on an inclined plane through a distance 3m. if the effort moved through a distance of 15m and efficiency of a system being 80%, calculate
- (i) Velocity ratio. (ii) Mechanical advantage.

(b)

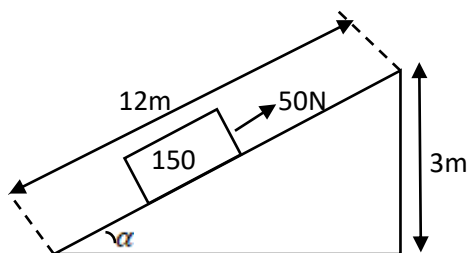

A load of 150N is raised on an inclined plane through a distance of 3m by an effort of 50N that moves through a distance of 12m. Calculate

- (i) Velocity ratio. (iii) Efficiency.
(ii) Mechanical advantage.

- (c) A load of 120N is raised through a height of 6m by an effort of 30N. If the load was 8m from the vertical plane before it was raised, calculate
- (i) Mechanical advantage. (iii) Efficiency of the system.
(ii) Velocity ratio.

4. (a) An hydraulic machine has 150teeth in driven gear and 50teeth in the driving gear.

Calculate

- (i) Velocity ratio.
(ii) Mechanical advantage if the efficiency of the system is 75%.

- (b) A car has a driving gear with 6teeth and a driven gear with 24teeth. If a force of 60N is used to drive a load of 180

5. (a)

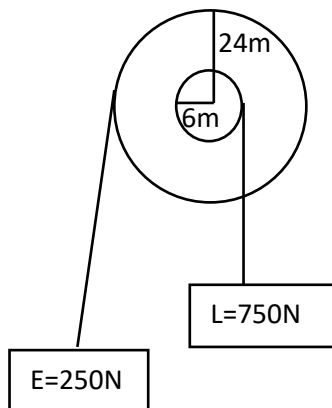

Calculate;

- (i) Velocity ratio. (iii) Energy wasted.
(ii) Mechanical advantage.

- (b) The diameter of the wheel and axle are 60cm and 10cm respectively. If the effort of 300N was used to raise a load of 1350N, calculate
- (i) Velocity ratio. (iii) Efficiency.
(ii) Mechanical advantage.

6. (a) Define the term pitch.

- (b) A screw jack with a lever arm of 56cm and a pitch of 2.5mm was used to raise a load of 800N. If its efficiency is 25%, find

- (i) Velocity ratio (ii) Mechanical advantage.

- (c) A car of mass 1600kg is raised using a screw jack of efficiency of 40%. If the pitch of the screw is 2mm and the turning bar is 30cm long. (Take $g=10\text{ms}^{-2}$). Calculate
- (i) Velocity ratio. (ii) Mechanical advantage.

- (iii) Effort applied.
- (d) An effort 20N is rotated to lift a load of 7500N in one turn of 80cm. If the pitch of the screw is 5mm, calculate
- (i) Mechanical advantage. (iii) Efficiency.
(ii) Velocity ratio.
- (e) A force of 300N is used to drive a load of 75N. If the car has driving gear with 24 teeth and a driven gear with 8 teeth, calculate
- (i) Mechanical advantage. (ii) Efficiency of the system.
7. (a) The efficiency of the hydraulic press is 60%. If the effort of 200N is applied on the piston of radius 5cm and the load is pressed on the piston of radius 30cm, calculate
- (i) Velocity ratio.
(ii) Mechanical advantage.
(iii) The load raised.

- (b) An hydraulic press has a main cylinder diameter of 30cm and a pump cylinder diameter of 1cm. calculate
- Velocity ratio.
 - Mechanical advantage if the force applied on the piston pump is 70N and efficiency is 80%.

MECHANICAL PROPERTIES OF MATTER

- Define the following terms as used in mechanical properties of material.
 - Strength.
 - Stiffness.
 - Ductility.
 - Elasticity.
 - Brittleness.
 - Plasticity.
 - State Hooke's law.
 - A spring increases its length from 2m to 6m when a force 20N is applied on the string. Calculate the spring constant.
 - A spring increase its length from 5cm to 10cm when a force of 12N is applied on the string. Calculate the spring constant.
 - Calculate the force applied when the length of spring changes from 3m to 5m and the spring constant being 20Nm^{-1} .
 - A force of 10N caused an extension of 2m when applied on a spring. Calculate the spring constant.
 - A force of 5N causes an extension of 3m when stretched. Calculate the extension produced when a force of 29N is applied on a spring.
 - A force of 6N causes an extension of 2m when stretched. Calculate the force that causes an extension 3m in the spring.
- Describe an experiment to verify Hook's law.
 - A graph below shows the variation of extension against load.

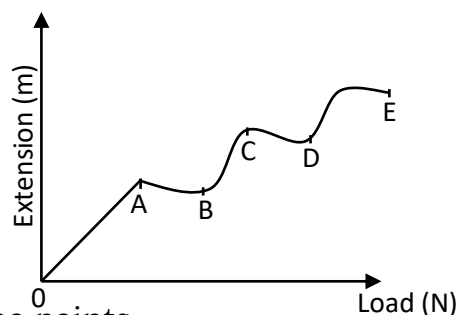

Name the points

- Point A
 - Point B
 - Point C
 - point D.
- (d) Explain the features of the graph at the following points.
- Point A
 - Point B
 - Point C
 - point D.

3.
 - (a) Define the following terms
 - (i) Tensile stress.
 - (ii) Tensile strain.
 - (iii) Young's modulus.
 - (b) A wire increases in length from 2m to 8m when a force is applied. Calculate the tensile strain.
 - (c) Calculate the tensile strain as the length of a wire changes from 3cm to 24cm when a force of 20N is applied.
 - (d) Calculate the tensile stress when a force of 30N acts on a wire of cross sectional area of 10m^2 .
 - (e) A wire of cross sectional 4m^2 increases in length from 6m to 18m when a force of 20N is applied. Calculate
 - (i) Tensile strain,
 - (ii) Tensile stress,
 - (iii) Young's modulus.

4.
 - (a) Define the following terms.
 - (i) A girder.
 - (ii) Shear force.
 - (iii) A strut.
 - (iv) A tie.
 - (b) Give two applications of girders.
 - (c)

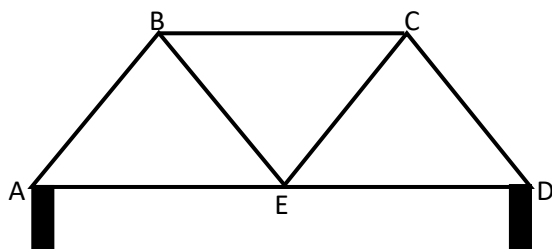

Name the girder that occurs

- (i) Between AE
 - (ii) Between AB
 - (iii) Between EC
5.
 - (a) Define the term notch.
 - (b) Explain how a beam with a notch on one side can be placed in making a bridge so as to obtain a stronger bridge.
 - (c) Give the method of reducing notch effect.
 - (d) Define the term concrete.
 - (e) Outline the characteristics of concrete which makes it a desirable material for building.
 - (f) Give the advantage of reinforced concrete.

NEWTON'S LAW OF MOTION

- 1)
 - (a) State the three Newton's laws of motion.
 - (b) Define the following terms
 - (i) Inertia.
 - (ii) Newton.
 - (iii) Momentum and give its S.I unit.
 - (c)
 - (i) Explain why a passenger when sited in a car moves forward when a car breaks or stops suddenly.

- (ii) Explain why a passenger standing on the floor of a lorry jerks backwards when the lorry starts moving forward.
 - (iii) Explain that happens to a person seated in a vehicle when it is suddenly brought to rest.
 - (iv) Explain why passengers in a vehicle need to fasten their seat belts.
 - (d) A body of mass 4kg travelling at 10ms^{-1} is accelerating to 16ms^{-1} in 20s. Calculate;
 - (i) The change in momentum.
 - (ii) Rate of change in momentum.
 - (iii) The applied force.
 - (e) A body of mass 300g moving at 5ms^{-1} is accelerated uniformly at 1ms^{-2} for 4s. calculate
 - (i) Change in momentum.
 - (ii) Rate of change in momentum.
 - (iii) The force acting on a body.
 - (f) Briefly explain what happens to an individual in a lift when it instantly;
 - (i) Moving upwards.
 - (ii) Moving downwards.
 - (iii) At rest.
 - (g) Find the reaction of a girl of mass 50kg standing in a lift. If the lift is;
 - (i) At rest.
 - (ii) Ascending upwards with uniform acceleration of 4ms^{-2} .
 - (iii) Descending downwards with uniform acceleration of 4ms^{-2} .
 - (h) Calculate the reaction of a boy of mass 100kg standing in a lift if the lift is;
 - (i) At rest.
 - (ii) Moving upwards with uniform acceleration of 5ms^{-2} .
 - (iii) Moving downwards with uniform acceleration of 5ms^{-2} .
- 2)
- (a) Define the following terms
 - (i) Linear momentum and state its S.I unit.
 - (ii) Inelastic collision.
 - (iii) Elastic collision.
 - (iv) Give the difference between inelastic collision and elastic collision.
 - (b) State the principle of conservation of linear momentum.
 - (c) (i) A body of mass 2kg travelling at 8ms^{-1} collides with a body of mass 4kg traveling at 10ms^{-1} in the same direction. If after collision the two bodies move together, calculate the velocity with which the two bodies move.
 - (ii) A body of mass 20kg traveling at 5ms^{-1} collides with another stationary body of mass 10kg and they move separately in the same direction. If the velocity of 20kg mass after collision was 2ms^{-1} , calculate the velocity of a stationary body after collision.
 - (iii) A body of mass 4kg travelling at 10ms^{-1} collides with a stationary object and they move together with a velocity of 5ms^{-1} . Calculate the mass of a stationary body.
 - (d) (i) A bullet of mass 20kg is fired with a velocity of 10ms^{-1} from a gun of 5kg. Calculate the recoil velocity of a gun.
 - (ii) A boy of mass 50kg jumps out of a boat of mass 100kg to the bank with a velocity of 4ms^{-1} . Calculate the velocity with which the boat begins to move backwards.
 - (e) Give the applications of the Newton's third law of motion and conservation of momentum.
 - (f) State the law of conservation of momentum.

- (g) Outline the facts on which linear momentum depends.
- (h) Explain what happens when a balloon is filled with air and then released in space without tying its open end.
- (i) Explain what happens to a passenger in a bus when the driver brakes suddenly.
- (j) Explain that happens to a parachutist who jumps from a high flying plane.
- (k) State the factors on which linear momentum depends.

3(a) A 2kg object moving with a velocity of 8ms^{-1} collides with a 3kg moving with a velocity of 6ms^{-1} along with the same direction. If the collision is completely inelastic, calculate the loss in kinetic energy.

(b) Two bodies A and B of mass 2kg and 4kg moving with a velocity of 8ms^{-1} and 5ms^{-1} respectively collide and move in the same direction. If object A has a velocity of 6ms after collision, calculate

- (i) The velocity of B after collision
- (ii) The loss in kinetic energy

(c) A particle of mass 2kg moving with a speed of 10ms^{-1} collides with a stationary particle of mass 7kg. immediately after impact, the particles move with the same speed but in opposite directions. Find the loss in kinetic energy.

2. a) State **Newton's laws of motion**.
- b) i) Explain why a person in a lift feels lighter while the lift begins moving downwards with an acceleration less than acceleration due to gravity.
- ii) A girl of mass 50kg stands in a stationary lift. Calculate apparent weight when accelerating upwards at a rate of 4ms^{-1}
- C) A body undergoing uniform acceleration has a velocity of 5ms^{-1} at one point and 25ms^{-1} at another point 120m away from the first point.
- i) Determine the acceleration of the body.
 - ii) Determine the momentum of the body after 8s.
 - ii) Sketch the velocity time graph for the motion.
- d) i) Distinguish between elastic and Inelastic collision.
- ii) Describe an experiment to determine acceleration due to gravity using a pendulum bob.

Week three

LINEAR MOTIONS

1. (a) Define the following terms as used in motion.
- (i) Speed.
 - (ii) Distance
 - (iii) Velocity.
 - (iv) Uniform velocity.
 - (v) Displacement.
 - (vi) Acceleration.
 - (vii) Uniform acceleration.

- (b) Differentiate between the terms speed and velocity.
- (c) A car travels a distance of 250km in 5 hours. Calculate the average speed in
 - (i) km/hr.
 - (ii) ms^{-1}
- (d) Sketch a distance – time graph showing
 - (i) A body at rest.
 - (ii) A body moving with uniform velocity.
 - (iii) A body moving with non – uniform velocity.
 - (iv) A body moving with decreasing acceleration (retardation).
- (e) Sketch a velocity – time graph showing;
 - (i) A body with uniform velocity.
 - (ii) A body moving with uniform acceleration.
 - (iii) A body moving with uniform deceleration.
 - (iv) A body moving with non uniform acceleration.

2. (a) A body starts from rest and reaches a speed up 4ms^{-1} after traveling with uniform acceleration in a straight line for 2s. Calculate
- (i) The acceleration of the body.
 - (ii) The distance traveled during that time.
- (b) A car starting from rest reaches a velocity of 20ms^{-1} in 5s with a uniform acceleration. Calculate
- (i) The acceleration.
 - (ii) Distance traveled in this time interval.
- (c) A body traveling at 10ms^{-1} is accelerated uniformly for 3 seconds at 5ms^{-2} . Calculate the final velocity.
- (d) A car starts from rest and accelerates for 10ms^{-2} a velocity 20ms^{-2} . It continues with this velocity for a further 20s before it is brought to rest in 20s.
- (i) Draw a velocity – time graph to represent the motion and calculate;
 - (ii) The acceleration of the car.
 - (iii) The deceleration of the car.
 - (iv) The distance traveled.
 - (v) The average speed.

(e)

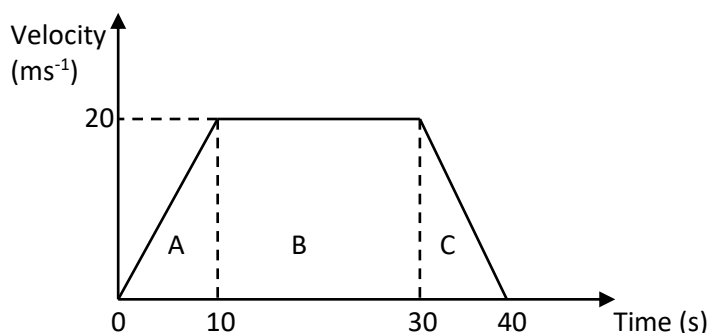

The diagram above represents a velocity – time graph for the motion of the body. Calculate;

- (i) The total distance travelled.
 - (ii) The average speed.
- (f) A car from rest accelerates to velocity 20ms^{-1} in 5s, it continues at uniform velocity for 15s and then decelerates so that it stops in 10s.
- (i) Draw a velocity – time graph to represent the motion and calculate;
 - (ii) The acceleration of the car.

- (iii) The deceleration of the car.
 - (iv) The distance travelled.
 - (v) The average speed.
- (g) The diagram below shows a velocity – time graph for a car in motion.

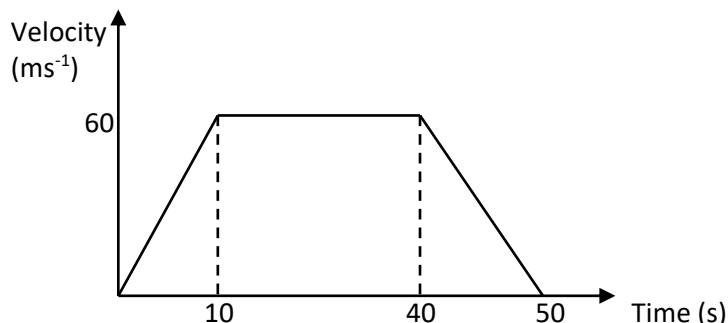

- (i) Find the total distance of the car.
 - (ii) Calculate the retardation of the car.
- (h) A car travelling at 10ms^{-1} is uniformly accelerated for 4s at 2ms^{-2} . It then moves with a constant speed for 5s after which it is uniformly brought to rest in another 3s. Draw a velocity – time graph for the motion of a car.
- (i) A car travels with a velocity of 10ms^{-1} for 3s. It then uniformly brought to rest in 2s. Draw a velocity – time graph for the motion of a car
- (j) The graph above represents a velocity- time graph for the motion of the body.

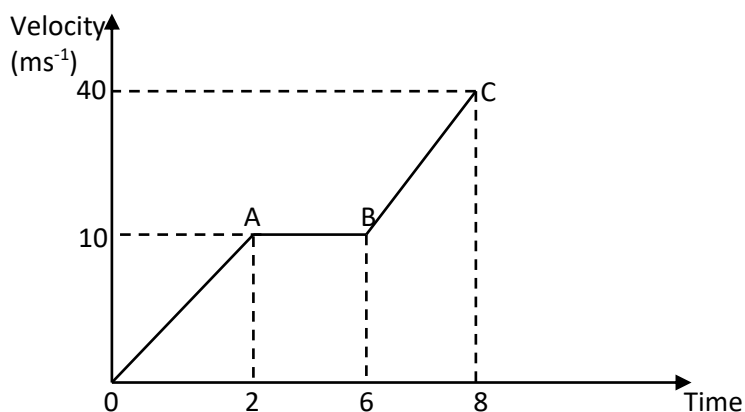

- (i) Calculate the acceleration of the body between OA, AB and BC.
 - (ii) Calculate the total distance traveled in 8s.
- (k) A body starts from rest and accelerates uniformly to a speed of 10ms^{-1} in 2s. It maintains this speed for 4s before accelerating uniformly again for another 2s.
- (i) Draw a velocity – time graph for the motion.
 - (ii) Find the highest speed attained by the body.
 - (iii) Calculate the acceleration of the body.
 - (iv) Calculate the total distance traveled

(l)

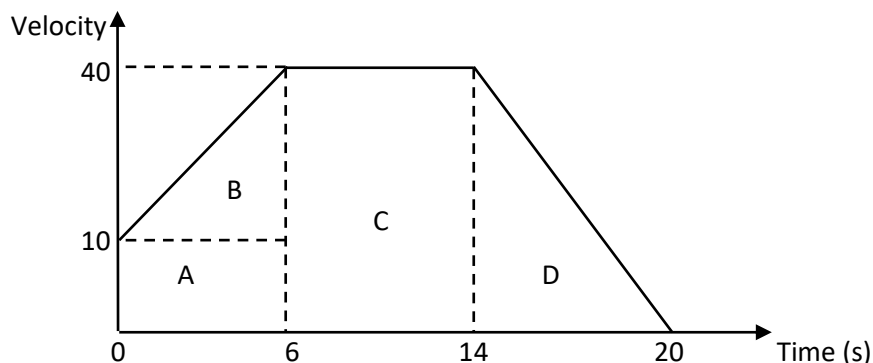

- (i) Calculate the total distance covered.
- (ii) Calculate the distance covered when the body was accelerating.
- (iii) Calculate the distance covered when the body has uniform velocity.

(m) The diagram above represents a velocity- time graph for the motion of the body.

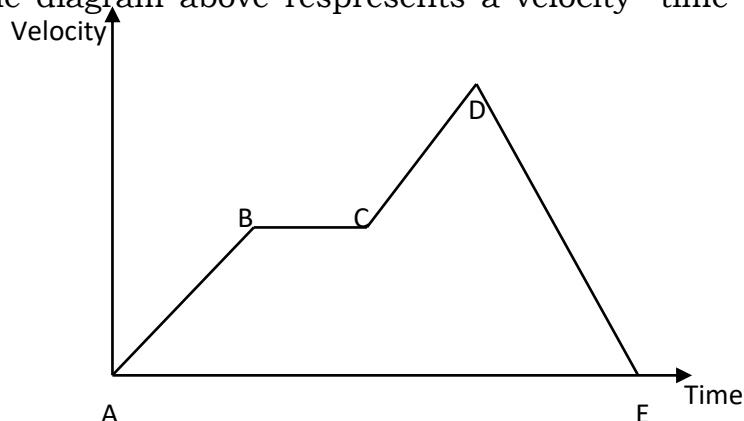

The diagram above represents a velocity – time graph for the motion of a body. Describe the motion of the body

- (i) Along AB
 - (ii) Along BC
 - (iii) Along CD
 - (iv) Along DE
- (n) Give three differences between acceleration and velocity.

MOTION UNDER GRAVITY

1. (a) An object is raised from rest at point 20m above the ground so as to fall freely vertically downwards.
 - (i) Find the time taken to land on the ground.
 - (ii) Find the velocity.
- (b) A ball is thrown vertically upwards with initial velocity of 30ms^{-1} .
 - (i) Find the maximum height to reach the ground.
 - (ii) Find the time taken to reach the maximum height.
 - (iii) Find the time taken to return to the starting point.

- (c) A stone is thrown vertically upwards with initial velocity 10ms^{-1} . If the air resistance is neglected;
- The maximum height reached.
 - The time taken before it reached the ground.
- 2.
- Sketch a distance – time graph for a body falling freely from rest.
 - An object falls from rest of the top of a house. Calculate the velocity after 2s.
 - An object is dropped from a top of a building. If the object hits the ground after 2s, calculate the height from which the object was dropped.
 - An object is dropped from an helicopter at a height of 20m. If the helicopter is at rest, find
 - How long an object takes to reach the ground.
 - The velocity on its arrival.
 - An object is released from an aircraft travelling horizontally with constant velocity of 100ms^{-1} at a height of 250m neglecting the air resistance.
 - Find how long it takes the object to reach the ground.
 - Find the horizontal distance covered by the object between leaving and reaching the ground.
 - A stone projected from top of a building at a horizontal velocity of 20ms^{-1} strikes the ground from the building. Find the height of the building.
 - An object is thrown vertically upwards with a velocity of 30ms^{-1} .
 - Calculate the time taken to reach the maximum height.
 - Find the time taken by the object to come back to the thrown level.
 - An object is thrown vertically upwards. If it reaches a maximum height of 20m,
 - Calculate the time it takes to reach the maximum height.
 - Find the time taken by the object to return to the starting point.
 - A stone is thrown horizontally from the top of a cliff at a horizontal velocity of 30ms^{-1} . If it takes 4s to reach the ground,
 - Find the height of the cliff.
 - Find the horizontal distance covered by the stone.
 - An object of 2kg is dropped from a helicopter at height 20m above the ground. If the air resistance is 0.4N, calculate
 - The acceleration.
 - The velocity.

CIRCULAR MOTION

1. (a) Define the term circular motion.
- (b)

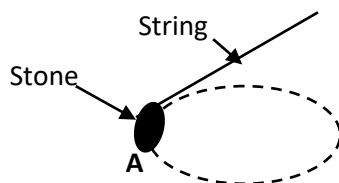

- The diagram above shows a stone fixed to one end of the string and then whirled (swung) in horizontal circular path. Copy the diagram and show on it the forces acting on the stone in position A.
- Explain what happens if the string breaks when the stone is in position A.

- (c) Give examples of objects moving in circular path.

HEAT

- 1 a) i) Define **heat transfer by radiation**.
ii) Figure 3 shows a long thin metal bar in equilibrium made of two parts connected at the ends with insulating material. Side A of the bar is brightly polished while side B is painted black. Two equal masses are suspended on the ends.

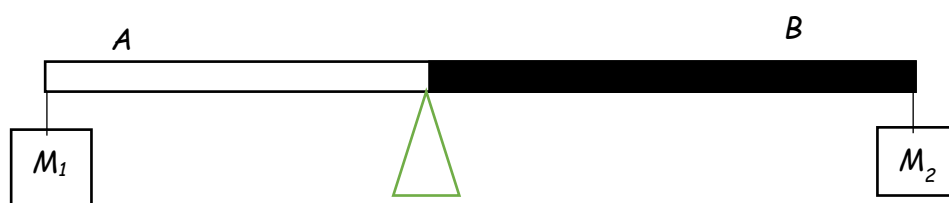

Explain what will be observed on the equilibrium of the bar if it is placed outside on a hot day.

- iii) State two devices designed using the factor demonstrated in 4a (ii) above.
- b) i) Define specific heat capacity.
ii) A student who wants to take a warm bath, opens hot water tap which delivers water at 10kg per minutes and a cold water tap which delivers water at 20kg per minute at a temperature of 18°C. if the taps are opened at the same time and are left running for 3 minutes, find the temperature of water from the hot- water tap if the final temperature of the warm water is 40°C. (SHC of water = 4200JKg⁻¹K⁻¹)
- c) Give **two** differences between boiling and evaporation.
- d) Explain the following observations.
i) Evaporation causes cooling.
ii) Scalds of steam burn are more severe than that of boiling water.
- e) i) State **Charles' law** as applied to gases.
ii) The volume of a fixed mass of a gas at 25°C and 74cmHg pressure is 100cm³. Find the volume of the gas at a pressure of 76cmHg and a temperature of 20°C.
- d) In order to ventilate a room well, it is advisable to have some ventilation close to the ceiling and some close to the floor. Explain why this is done?

LIGHT

- 1 a) i) What is meant by the term **rectilinear propagation of light**. (1 mark)
- ii) Draw a labelled diagram to show the formation of shadows from an extended source of light. (3 marks)
- b) Distinguish between a **virtual image** and a **real image**. (2 marks)
- c) With the aid of a diagram describe why a convex mirror is suitable for use as a driving mirror. (2 marks)
- d) An object is placed 15cm in front of a concave mirror. An upright image of magnification 4 is produced by graphical method; determine the
- i) focal length of the mirror.
- ii) Nature of the image
- iii) the distance of image from the mirror. (5 marks)
- e) Describe an experiment to determine the accurate focal length of a concave mirror using an illuminated object. (4 marks)
- f) With the aid of a diagram, explain why a parabolic mirror is suitable for use in can lead lamps. (3 marks)
- 2 a) State the laws of **refraction of light**.
- b) Describe an experiment to determine the refractive index of a glass block.
- c) A ray of white light is incident on an equilateral glass prism as shown in the diagram.

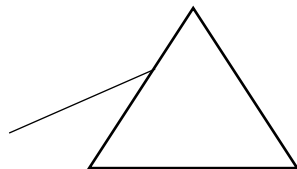

- i) Draw the diagram to show how the light emerges from the prism.
- ii) Name the property of light demonstrated by the prism.
- iii) Describe how the emergent light can be observed.
- d) i) What are complementary colours.
- ii) Give **two** examples of complementary colours.
- iii) A student wearing a red shirt with green strips passes over a blue light. Describe the appearance of the shirt.

- e) A concave lens has a focal length of 20cm. calculate its power.

ELECTROSTATICS AND ELECTRICITY

- 1 a) i) State the law of **electrostatics**.
ii) When a negatively charged rod is brought near the brass cap of a positively charged electroscope, it is noted that gold leaf starts to collapse but when the rod is brought much closer, the leaf starts to rise. Explain this observation.
iii) Sketch the electric field lines due to the charge distribution shown in fig (4)



- b) i) Explain why it not advisable to carry out that process when it is raining.
ii) Describe how a gold leaf electroscope can be charged negatively by induction.
- c) Explain the action of a lightning conductor.
d) State any **one** device that uses static electricity.
- 2 a) Define the following terms
i) **A volt**
ii) **Internal resistance**
iii) **Electromotive force** (3 marks)
b) Distinguish between **primary** and **secondary cells**. (2 marks)
c) i) With the aid of a diagram, explain how an accumulator is charged. (4 marks)
ii) Give **four** precautions which the life of an accumulator is prolonged. (2 marks)

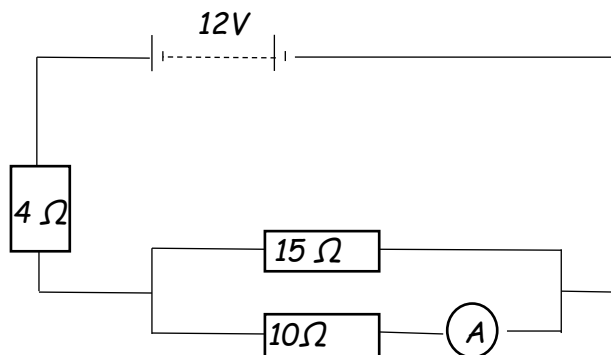

d) .

The circuit diagram in fig 5 shows resistors of resistances $4\ \Omega$, $15\ \Omega$ and $10\ \Omega$ connected across a 12V battery of negligible internal resistance. Find the ammeter reading.

(4 marks)

e) Briefly explain why a fuse is always connected to live wire in an electrical appliance.

(1 mark)

f) Three identical bulbs, each rated at 6V , 3W are used to investigate the various combinations of them when connected to a 6V source.

i) How many combinations of the three bulbs are possible?

ii) Find the minimum and maximum power consumption during these investigations.

(4 marks)

Week four

WAVES

1 a) Define the following terms used in waves.

i) **Period** (1 mark)

ii) **Amplitude** (1 mark)

iii) **Wave length** (1 mark)

iv) **Frequency** (1 mark)

b) A water wave moves from shallow to deep water, what effect does this have on its frequency and wave length. (2 marks)

c) i) What is meant by **reverberation**. (1 mark)

ii) Mention any **one** importance of reverberation. (1 mark)

ii) Describe an experiment to determine the speed of sound in air by echo method. (4 marks)

d) In an experiment to determine the speed of sound in air, a drum at a point 150m from a vertical wall was struck at varying frequencies while listening to the echo. The echo coincided with the sound from the drum and then more 20 successive strikes were made within a time of 18.5 seconds.

- i) Determine the time for the echo to be heard. (1 mark)
- ii) calculate the speed of sound in air at the location (2 marks)
- iv) What difference would you expect if the experiment is repeated on a cold day? (1 mark)
- e) state and explain the factors which affect the frequency of a vibrating string. (4 marks)

MODERN PHYSICS

- 1 a) Define the following terms:
 - i) **atomic number**
 - ii) **mass number**
 - iii) **isotopes**
- b) The equation below shows a nuclear reaction

$${}^2_1\text{H} + {}^3_1\text{H} \longrightarrow {}^4_2\text{He} + {}^1_0\text{n}$$
 - i) What reaction is represented in the equation?
 - ii) State the conditions necessary for the reaction to occur.
- c) A nuclide sample has a half-life of 4 hours. What percentage of the original number of atoms of the atoms of the radioisotope would be left after 20 hours?
- d) Give **two** applications of radioactivity in industries.
- e) i) Define **thermionic emission**.
 - ii) Draw a well labelled diagram of a cathode ray oscilloscope and state the functions of the main parts.
 - iii) Explain why all tubes for electron flow are always evacuated?

MAGNETISM

- 1 a) i) What is a **neutral point** as applied to magnetic field?
 - ii) List **four** features of magnetic flux.
 - iii) Draw a diagram of the magnetic field pattern when a bar magnet is placed in the earth's magnetic field with its south pole facing the geographical North.
- b) State Faraday's law of electromagnetic induction.
- c) A transformer supplies a current of 13.5A at a voltage of 48V to a device from an a.c mains supply of 240V. Given that the transformer is 90% efficient, calculate;
 - i) the power wasted
 - ii) the current in the primary circuit.
- d) i) state any **two** factors that lead to energy loss in a transformer.

- ii) Briefly explain why it is not advisable to fix the switch of a light bulb inside the bathroom.

Archimedes and floatation

1. (a) State the Archimedes principle.
(b) With the aid of a diagram describe an experiment to verify Archimedes principle.
(c) (i) A body weighs 40N in air, 15N when wholly immersed in water. Calculate the upthrust.
(ii) A body weighs 10N in air, when wholly immersed in water it appears to weigh 6N. Calculate the weight of water displaced.
(d) A metal weighs 30N in air and 10N when fully immersed in water. Calculate;
(i) Upthrust.
(ii) Weight of displaced water.
(iii) Volume of displaced water if density of water = 1000kgm^{-3} . (Take $g = 10\text{ms}^{-2}$)
(iv) Volume of metal.
(v) Density of metal.
(e) A stone weighs 8N in air and 6N when totally immersed in water. Calculate
(i) Upthrust.
(ii) Weight of displaced water.
(iii) Volume of displaced water if density of water = 1000kgm^{-3} . (Take $g = 10\text{ms}^{-2}$)
(iv) Volume of stone
(v) Density of stone.
(f) Give two applications of Archimedes principle.
(g) (i) An object weighs 20N in air and 5N in water. Find the relative density.
(ii) An object of relative density 2 weighs 10N in air. Find the weight of the object in water.
(h) (i) An object weighs 50N in air, 30N in water and 10N when immersed in a liquid. Find the relative density of air.
2. (a) State the law of floatation.
(b) (i) Describe an experiment to verify the law of floatation.
(ii) What happens to the body when the weight of the body is greater than the upthrust?
(iii) What happens to the body when the weight of the body is less than the upthrust?
(c) (i) Explain why a ship is able to float on water.
(ii) Explain why submarines are able to sink and travel below water.
(d) Give the applications of the law of floatation.
(e) Explain why airships are able to fly in space.
(f) Define the term upthrust.
3. (a) Name the three forces that act on a body when it falls through a fluid.
(b) Name the velocity attained by a body as it continues to fall through a fluid.
(c) Define the term terminal velocity.
(d) Draw a graph to show the variation of terminal velocity with time.

4. (a) A wooden sphere of mass 6kg and volume 0.02m^3 floats on water. Calculate
- (i) Volume of the sphere below the surface of water.
 - (ii) Density of the wood.
 - (iii) Fraction of the volume of the sphere that would be submerged if it floats in a liquid of density 800kgm^{-3} .
- (b) The mass of an object 0.5gcm^{-3} is 40g. What fraction of the object is immersed when it floats in water?
- (c) The solid of volume $1 \times 10^{-4}\text{m}^3$ floats on water of density $1 \times 10^3\text{kgm}^{-3}$ with $\frac{3}{4}$ of its volume submerged. Find
- (i) The mass of solid.
 - (ii) The density of solid.
- (d) When a metal is completely immersed in a liquid A its apparent weight is 40N. When immersed in another liquid B the apparent weight is 32N. If the density of B is $\frac{3}{4}$ times that of A, calculate the mass of the metal.
- (e) A rubber ballon of mass $5 \times 10^{-3}\text{kg}$ is inflated with hydrogen and held stationary by means of a string. If the volume of the inflated ballon is $5 \times 10^{-3}\text{m}^3$, the density of hydrogen = 0.8kgm^{-3} , the density of air = 1.15kgm^{-3} . Calculate the tension in the string.
- (f) Explain why a cork stopper held below the surface of water rises when released.

**NICE HOLIDAY
STAY AT HOME**